

Robin Industrial Engines®

PARTS MANUAL

Model

REDUCTIONS

1193P243



ROBIN AMERICA, INC.
ROBIN TO WISCONSIN ROBIN
ENGINE MODEL CROSS REFERENCE LIST

ROBIN

WISCONSIN ROBIN

SIDE VALVE

EY08	W1-080
EY15	W1-145
EY15V	W1-145V
EY20	W1-185
EY20V	W1-185V
EY23	W1-230
EY28	W1-280
EY35	W1-340
EY40	W1-390
EY45V	W1-450V
EY21	EY21W
EY44	EY44W
EY18-3	EY18-3W
EY25	EY25W
EY27	EY27W

OVERHEAD VALVE

EH11	WO1-115
EH12	WO1-120
EH15	WO1-150
EH17	WO1-170
EH21	WO1-210
EH25	WO1-250
EH30	WO1-300
EH30V	WO1-300V
EH34	WO1-340
EH34V	WO1-340V
EH43V	WO1-430V

TWO CYCLE

EC13V	WT1-125V
-------	----------

DIESEL

DY23	WRD1-230
DY27	WRD1-270
DY30	WRD1-300
DY35	WRD1-350
DY41	WRD1-410

6:1 GEAR REDUCTION UNIT



Page 1-2 **Maintenance** (Instructions for changing position of take-off shaft)

Page 2 **Overhaul**

Page 3-4 **Service Parts List**

Maintenance

Before starting new engine, fill engine crankcase and gear reduction unit to indicated oil levels with a good quality engine oil. Refer to your "Operators Manual" for engine crankcase oil recommendations. The following are lubricating instructions for the gear reduction unit:

S.A.E. 30 for spring, summer or fall operation.
S.A.E. 20 for winter operation.

Remove filler and level plugs. Note: when remounting, the filler plug has a vent hole. Pour oil through filler opening until it runs out through level hole. About 3/8 pint (177 cc) is required. Install oil level plug and vented filler plug.

When changing engine crankcase oil, check reduction unit and add oil if necessary to maintain proper level.

Every 500 hours of operation, or sooner if oil becomes dirty, change oil in reduction unit. To drain oil: with engine warm, place pan under reduction unit and loosen cover. Once a year remove cover completely and flush out inside of housing with kerosene. Do not use gasoline for cleaning.

Vented filler plug should be removed periodically and the vent hole should be thoroughly cleaned. Ventilation is necessary to eliminate pressure build-up (causing oil leaks) and to prevent condensation from forming in the housing.

TAKE -OFF SHAFT POSITION

The standard location of the take-off shaft is to the right, in a 3 o'clock position facing the shaft end of the engine as illustrated in Figure 1. Three other positions are obtainable: above, below or to the left of the engine center-line .

TO CHANGE SHAFT POSITION

The mounting holes of the housing are equally spaced so that the reduction unit can be rotated without too much difficulty to obtain either a 6, 9 or 12 o'clock take-off shaft position.

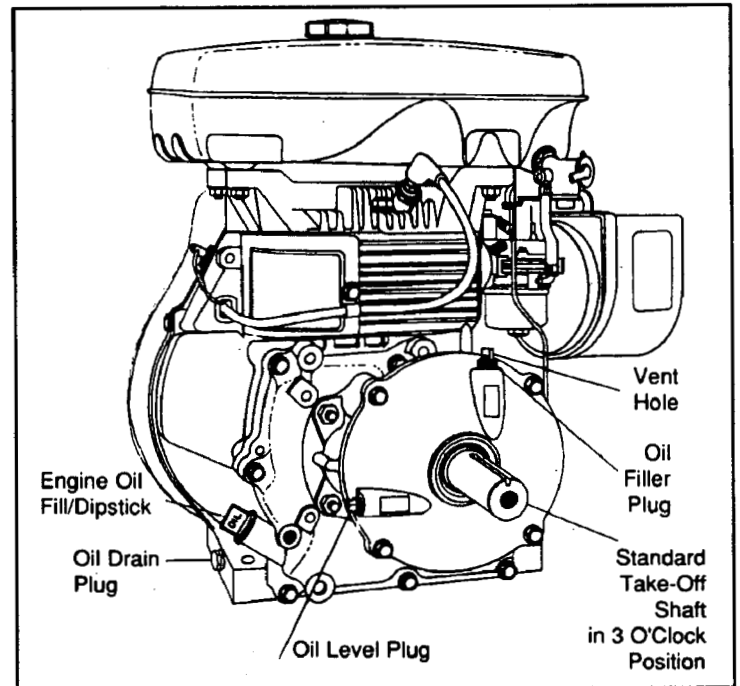

Figure 1

Technical Information:

Rotation:	Counterclockwise
Shaft dimensions:	
EY18-3W, EY15, EY20	3/4 dia., 3/16" Sq. Key
EY25W, EY27W, EY28	1" dia., 1/4" Sq. Key
3/8" - 24 Tap in end of shaft (all models)	
Take-off shaft position:	3 o'clock standard Optional 6, 9 and 12 o'clock positions
Total weight (dry)	Engine with Reduction Unit
EY15:	35 lbs (16.0 kg)
EY20:	39 lbs (17.8 kg)
EY18-3W:	50 lbs (22.7 kg)
EY28:	53 lbs (24.0 kg)
EY25W/27W:	60 lbs (27.2 kg)
Ball bearing support:	Both ends of take-off shaft
Housing and cover:	Cast-aluminum
Driving gear:	Machined on end of crankshaft
Forged steel take-off shaft:	With driven ring gear (an integral part of forging)

6:1 GEAR REDUCTION UNIT

1. With reference to Figure 4, the exploded view on page 4, place pan under unit to drain oil as cover is removed. Take out four cap screws, lockwashers and plain washers. NOTE: the mounting screws are metric thread, 8mm x 25mm long. Tag these for identification so as not to mistake them in reassembly with the 5/16 - 24 NF thread screws.

2. Tap around outer perimeter of cover with a soft hammer to loosen cover from housing. Remove cover assembly, being careful not to damage oil seal and gasket.

3. With reference to figure 2 (below) use a slide hammer-type puller, or similar tool, screwed into the 3/8 - 24 tap in end of take-off shaft, to loosen and remove shaft gear assembly from housing.

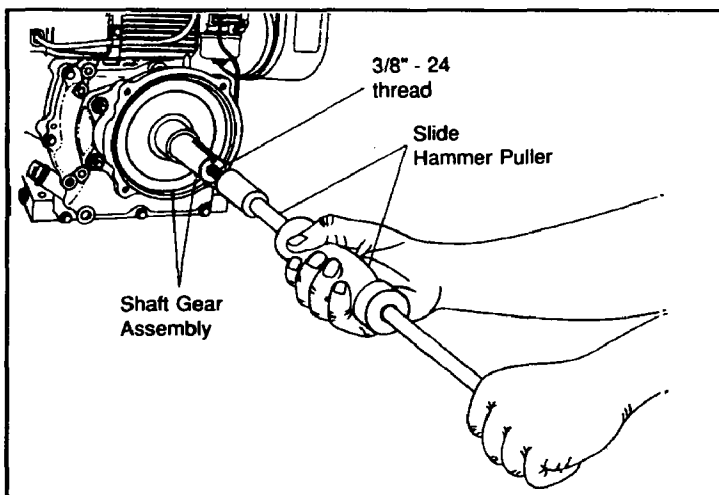

Figure 2

4. With reference to Figure 3, straighten lock tabs on hex of inner mounting screw heads, loosen and remove two inner and two outer housing mounting screws and washers. NOTE: the two outer screws should be tagged as 5/16 - 24 x 1 inch long so as not to be mistaken for the 8mm x 25mm long screws removed earlier.

5. Remove housing, being careful not to damage flange gasket.

6. An adapter plate is mounted between the gear cover and the reduction housing on model EY25W previous to serial number 576763 and model EY27W previous to serial number 75032. All other models have reduction housings mounted directly to the engine gear cover (no adapter is required).

REASSEMBLY

1. With gasket in place, mount housing, with pilot bearing shown in Figure 3, to the right, left, above or below the crankshaft drive gear, depending on desired take-off shaft location.

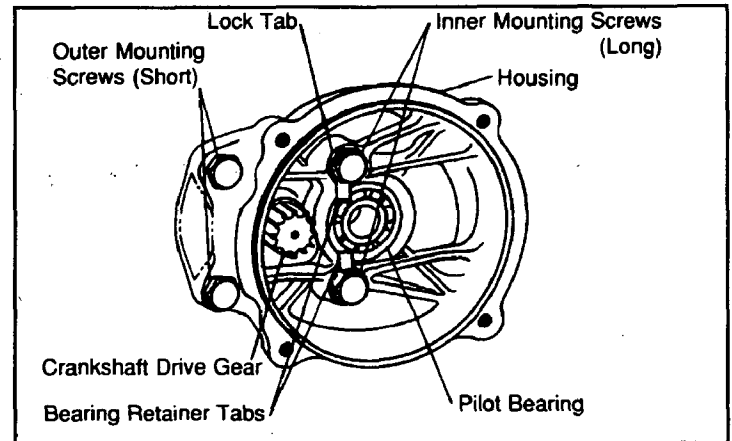

Figure 3

2. Mount the two inner (1-3/4 inch long) screws and tab lock washers, and two outer (1 inch long) screws, lock washers and plain washers. Tighten screws to 12.5 ft. lbs.(1.7 kgm) torque. One set of tabs on the two inner screw lock washers is formed to serve as a retainer for the pilot bearing. The other tabs are bent perpendicular to the flat of the screw hex to lock screws in place.

3. Engage driven gear, with gear on end of crankshaft, and inner end of take-off shaft with pilot bearing. Tap end of shaft lightly until it shoulders against pilot bearing. Turn crankshaft over to test for unrestricted operation of gear and shaft.

4. Mount gasket and cover. Be careful not to damage lips of oil seal. Use an oil seal sleeve over end of take-off shaft (same as used for engine gear cover oil seal), if available. Caution: be sure that oil filler boss with vented plug is toward the top of the reduction unit cover. Mount labels to suit.

Mount the four metric thread screws, lock washers and plain washers. Tighten to 12.5 ft. lbs.(1.7 kgm) torque.

5. Add S.A.E. 20 or 30 weight oil to the unit, through filler plug opening, to opening of level plug. Approximately 3/8 pint (177 cc) is required. Check for oil leaks.

The change-over is complete and ready for operation.

Overhaul

The same disassembly and reassembly procedures for changing shaft position are to be followed for overhaul. Check parts for excessive wear and replace if necessary. Use new gaskets in reassembly. See next page for Service Parts List.

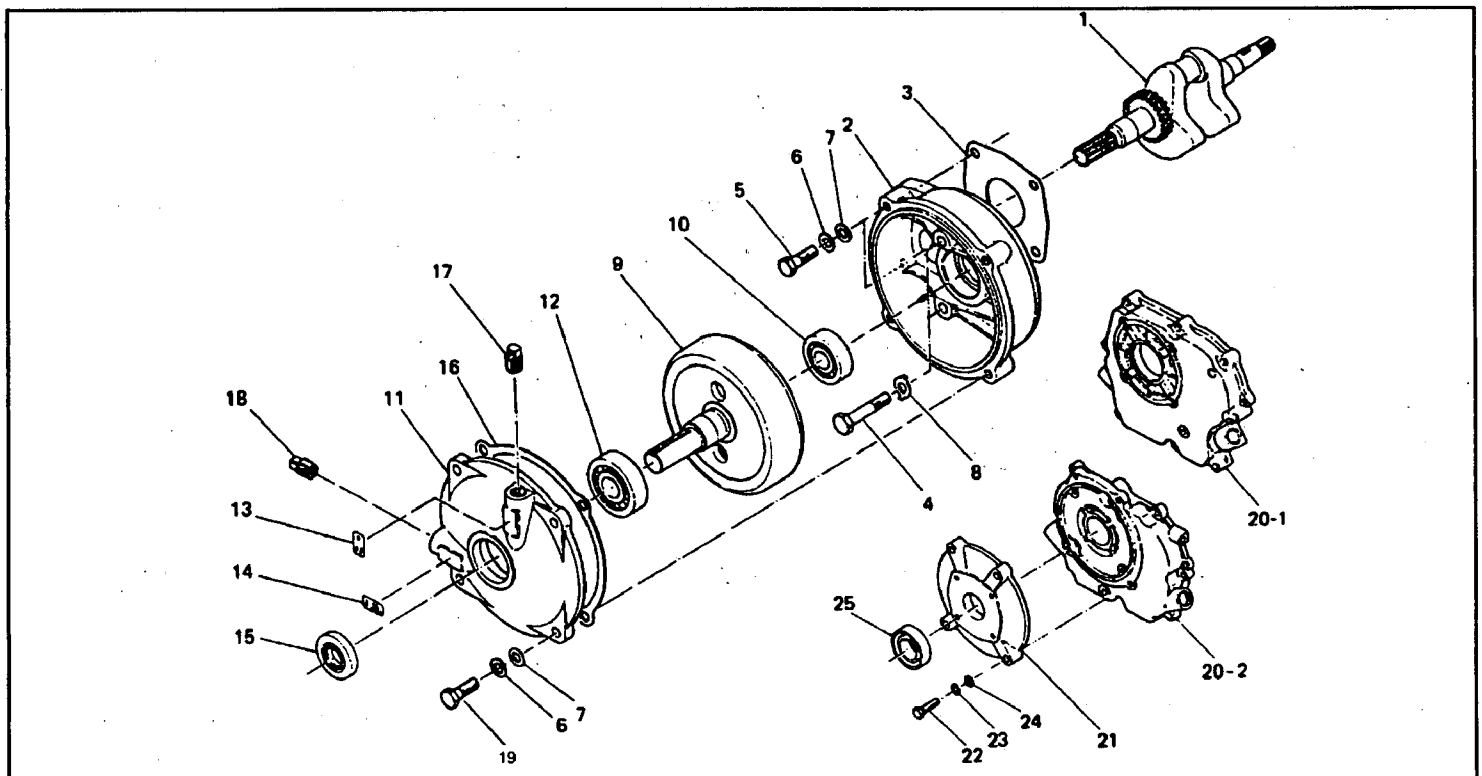

Figure 4, Gear Reduction Exploded

ITEM	PART NO.	DESCRIPTION	QTY
1	226 21701 51	Crankshaft EY15 (TIC)	1
-	227 21701 51	Crankshaft EY20 (TIC)	1
-	226 21702 01	Crankshaft EY15 (Point)	1
-	227 21702 01	Crankshaft EY20 (Point)	1
-	214 20401 01	Crankshaft EY18-3W	1
-	232 20701 01	Crankshaft EY23	1
-	*207 29301 11	Crankshaft EY25W	1
-	**207 29301 11	Crankshaft EY27W	1
-	234 20801 11	Crankshaft EY28	1
2	207 80101 01	Reduction Case (Includes Item 10)	1
-	234 80101 01	Reduction Case (For EY28)	1
-	226 80101 01	Reduction Case (For EY15 Spec.WR1050/800433)	1
3	206 85101 03	Gasket (Only For EY28)	1
4	010 10800 30	Bolt	2
5	010 10800 80	Bolt	2
6	003 20080 00	Lock Washer	2
7	003 10080 00	Washer	2
8	003 38080 00	Lock Washer	2
9	206 81101 13	Driving Shaft (EY18-3W,EY15,EY20)	1
-	207 81101 13	Driving Shaft (EY28,EY25W,EY27W)	1
-	226 81101 03	Driving Shaft (EY15 Spec.WR1050/800433)	1
-	227 81101 03	Driving Shaft (EY15 Spec.WR1080/800821,WR1030/800403) (EY20 Spec.WR1040/800404,WR1060/800886) (EY23 Spec.WR1000/800814)	1
9	234 81101 03	Driving Shaft (EY2 Spec.WR4010/800473,WR4020/800815) (EY23 Spec.WR1010/800905)	1

* For models previous to serial number 576763, use crankshaft 207 29301 01, and gear cover part number 207 11001 01.

** For models previous to serial number 75032, use crankshaft 207 29301 01, and gear cover part number 207 11001 01.

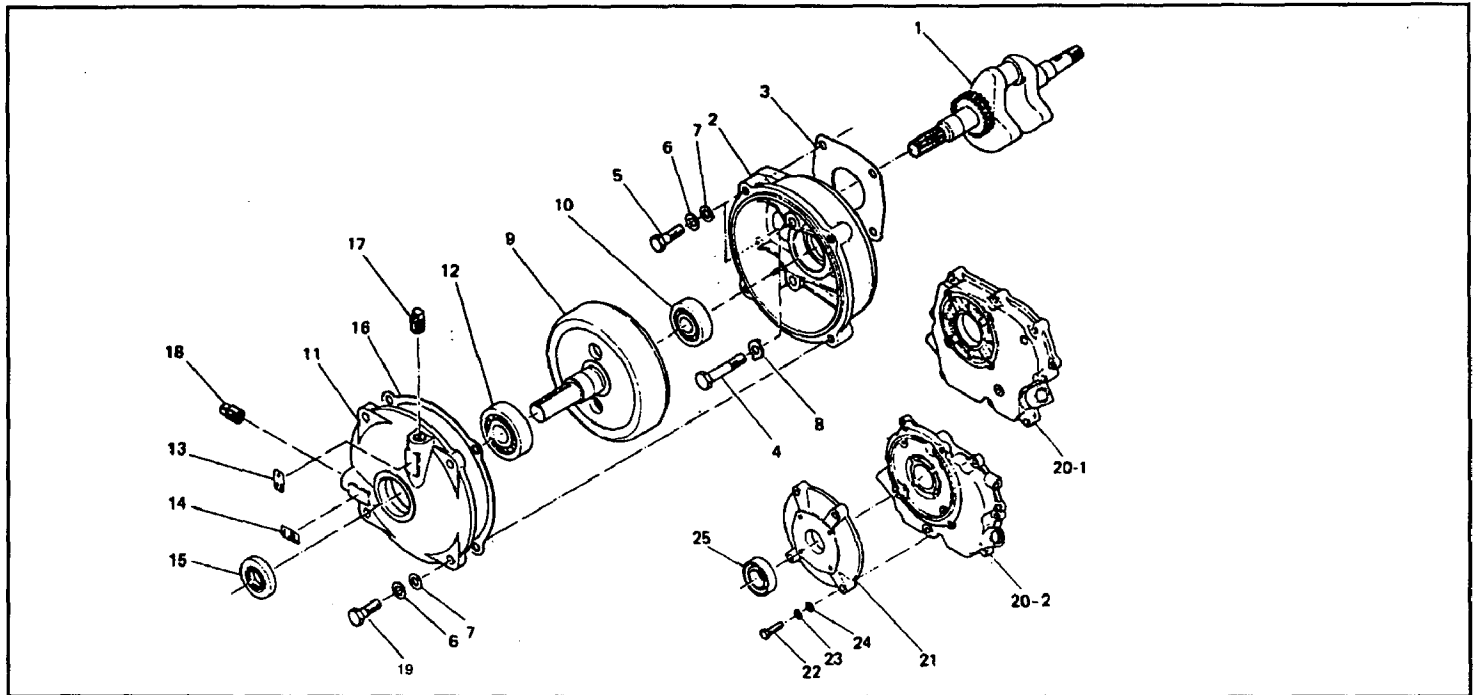

Figure 4, Gear Reduction Exploded View

ITEM	PART NO.	DESCRIPTION	QTY
10	060 01500 20	Ball Bearing	1
11	214 80601 01	Reduction Cover (Includes Items 12-15) (EY18-3W,EY15,EY20)	1
-	207 80701 01	Reduction Cover (Includes Items 12-15) (EY28,EY25W,EY27W)	1
12	060 02500 10	Ball Bearing (EY15,EY20,EY18-3W)	1
-	060 03000 20	Ball Bearing (EY28,EY25W,EY27W)	1
13	206 95001 03	Label, Oil Filler	1
14	206 95002 03	Label, Level Mark	1
15	044 02500 70	Oil Seal (EY15,EY20,EY18-3W)	1
-	044 03000 30	Oil Seal (EY28,EY25W,EY27W)	1
16	206 85102 03	Gasket	1
17	206 85001 03	Plug	1
18	206 85002 03	Plug	1
19	001 14082 50	Bolt & Washer	4
20-1	227 11002 21	Gear Cover (EY15, EY20)	1
20-2	*207 11801 01	Gear Cover (EY25W)	1
-	** 207 11801 01	Gear Cover (EY27W)	1
-	234 12003 01	Gear Cover (EY28)	1
-	214 11008 01	Gear Cover (EY23)	1
21	207 85201 03	Adapter (EY25W, EY27W)	1
22	010 11000 10	Bolt (EY25W, EY27W)	4
23	003 20100 00	Lock Washer (EY25W, EY27W)	4
24	003 10100 00	Washer (EY25W, EY27W)	4
25	044 02500 20	Oil Seal	1

Note: Items 21 through 25 are required for EY25W models previous to serial number 576763, and are also required for EY27W models previous to serial number 75032.

*For models previous to serial number 576763, use crankshaft part number 207 29301 01, and gear cover part number 207 11001 01.

**For models previous to serial number 75032, use crankshaft part number 207 29301 01, and gear cover part number 207 11001 01.

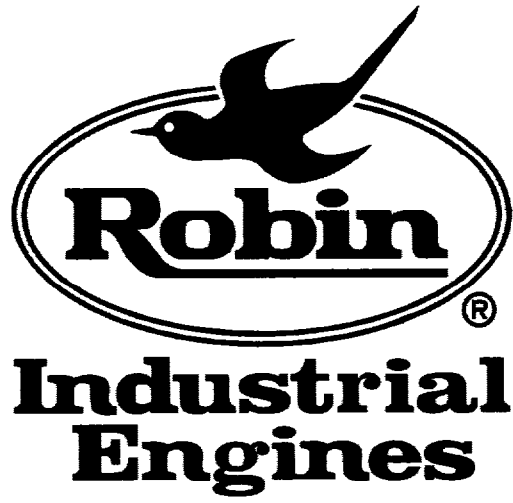

Robin America, Inc.

940 Lively Blvd., Wood Dale, IL 60191 • Tel: (708) 350-8200 • Fax: (708) 350-8212