

Robin Industrial Engines®

SERVICE MANUAL

Model

EC02

1193S117



ROBIN AMERICA, INC.
ROBIN TO WISCONSIN ROBIN
ENGINE MODEL CROSS REFERENCE LIST

ROBIN

WISCONSIN ROBIN

SIDE VALVE

EY08	W1-080
EY15	W1-145
EY15V	W1-145V
EY20	W1-185
EY20V	W1-185V
EY23	W1-230
EY28	W1-280
EY35	W1-340
EY40	W1-390
EY45V	W1-450V
EY21	EY21W
EY44	EY44W
EY18-3	EY18-3W
EY25	EY25W
EY27	EY27W

OVERHEAD VALVE

EH11	W01-115
EH12	W01-120
EH15	W01-150
EH17	W01-170
EH21	W01-210
EH25	W01-250
EH30	W01-300
EH30V	W01-300V
EH34	W01-340
EH34V	W01-340V
EH43V	W01-430V

TWO CYCLE

EC13V	WT1-125V
-------	----------

DIESEL

DY23	WRD1-230
DY27	WRD1-270
DY30	WRD1-300
DY35	WRD1-350
DY41	WRD1-410

CONTENTS

<i>Section</i>	<i>Title</i>	<i>Page</i>
1.	SPECIFICATIONS	1
2.	PERFORMANCE	2
2-1.	Maximum Output	2
2-2.	Continuous Rated Output	2
2-3.	Maximum Torque and Fuel Consumption Ratio and Max. Output	2
3.	FEATURES	3
4.	DISASSEMBLY and REASSEMBLY	4
4-1.	Preparation and Suggestions	4
4-2.	Special Tools	4
4-3.	Disassembly Procedures	5
4-4.	Reassembly Procedures	6
5.	BREAKER POINT ADJUSTMENT PROCEDURES	9
6.	CARBURETOR ADJUSTMENT	10
7.	OPERATION OF FLOAT DIAPHRAGM CARBURETOR	11
8.	TROUBLE SHOOTING	13
9.	CHECKS and CORRECTIONS	16
10.	MAINTENANCE and STORING	19
10-1.	Daily Checks and Maintenance	19
10-2.	Every 50 Hours Checks and Maintenance	19
10-3.	Every 150 Hours Checks and Maintenance	19
10-4.	Yearly Checks and Maintenance	19
10-5.	Preparation for Long Abeyance	19

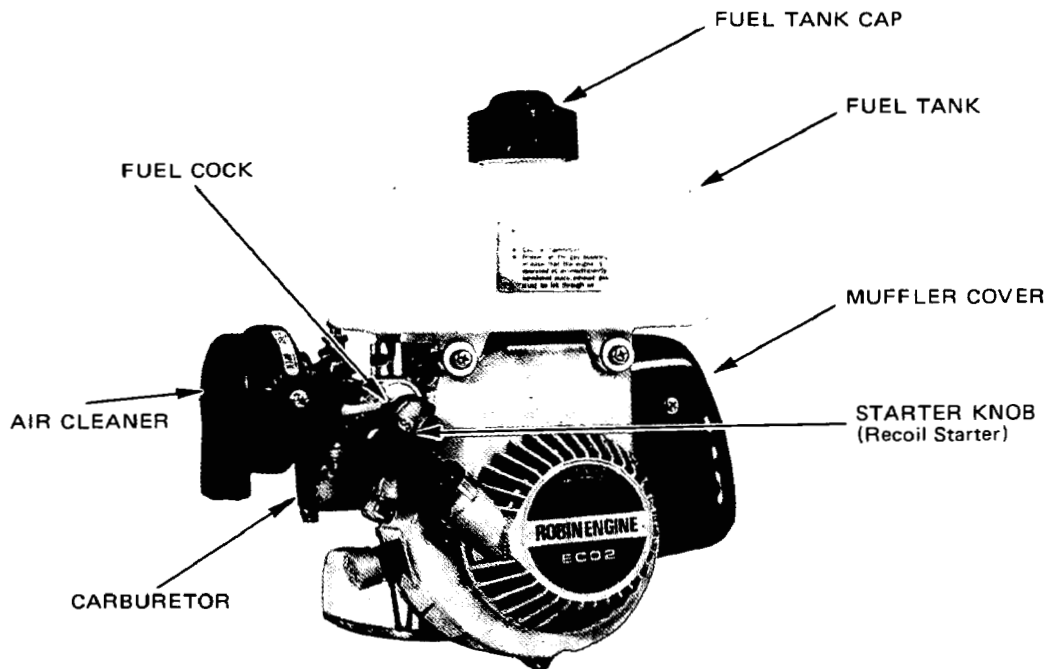
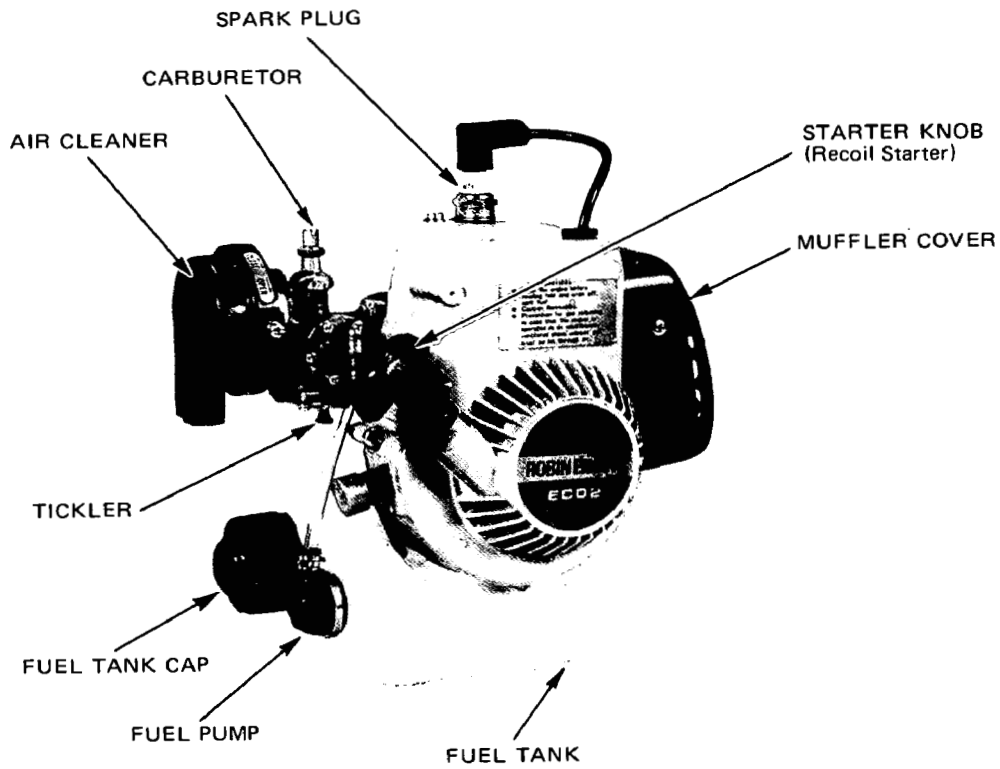

1. SPECIFICATIONS

Model		EC02-A	EC02-R
Type		Air-Cooled, 2-Cycle, Upright Single Cylinder, Horizontal P. T. O. shaft	
Bore x Stroke (in)		32mm x 28mm (1.26 x 1.10)	
Piston Displacement (cu. in)		22.5cc (1.37)	
Compression Ratio		6.5	
Output	Continuous	0.73HP/6,000 rpm	
	Max.	1.1 HP/7,000 rpm	
Max. Torque		0.116kg-m/6,000 rpm	
Direction of Rotation		Counter-clockwise, viewed from driving shaft (P.T.O. shaft) side	
Cooling System		Forced Air Cooling	
Lubrication		by mixed Lubricating Oil in Fuel	
Lubricant		2-Cycle engine Oil only	
Carburetor		Horizontal Draft Float Type	Horizontal Draft Diaphragm Type
Fuel		Mixture Fuel (Gasoline 20 ~ 25 : Oil 1)	
Fuel Consumption Ratio		420g/HP-h at 0.73HP/6,000 rpm	
Fuel Feed System		Gravity Type	Diaphragm Pump Type
Fuel Tank Capacity		Approx. 0.6 liter (0.16 U.S. gal.)	Approx. 0.5 liter (0.13 U.S. gal.)
Ignition System		Flywheel Outer-Coil Magneto Type	
Spark Plug		NGK BM-7A	
Starting Method		Recoil Starter	
Dry Weight (lbs.)		2.2kg (4.9)	
Dimensions (in)		139mm (5.5) length x 232mm (9.1) width x 254mm (10) height	139mm (5.5) length x 239mm (9.4) width x 246mm (9.7) height

2. PERFORMANCE

2-1 MAXIMUM OUTPUT

The maximum output of the EC02-A and EC02-R is such standard power as developed by the engine, after its run-in period with all the moving parts properly worn-in, when operating with the fully open throttle valve. Therefore, it follows that a new engine may not develop this maximum output in the beginning, because moving parts are not in a properly worn-in condition.

2-2 CONTINUOUS RATED OUTPUT

The continuous rated output of the EC02-A and EC02-R is such power as developed by the engine when running at an optimum speed most favorable in view of engine life and fuel consumption ratio. Therefore, it follows that when designing a driving system for any mechanism, with the engine, as a prime mover, the continuous power requirement of that mechanism must be kept below the continuous rated output specified.

2-3 MAXIMUM TORQUE and FUEL CONSUMPTION RATIO at MAX. OUTPUT

The maximum torque of the EC02-A and EC02-R is that driving torque of the driving shaft at which the engine is driving an external load, while the engine is pulling its max. output. The fuel consumption ratio at max. output is that fuel consumption ratio of the engine while the engine is running at the max. output.

MODEL EC02-A and EC02-R PERFORMANCE CURVE

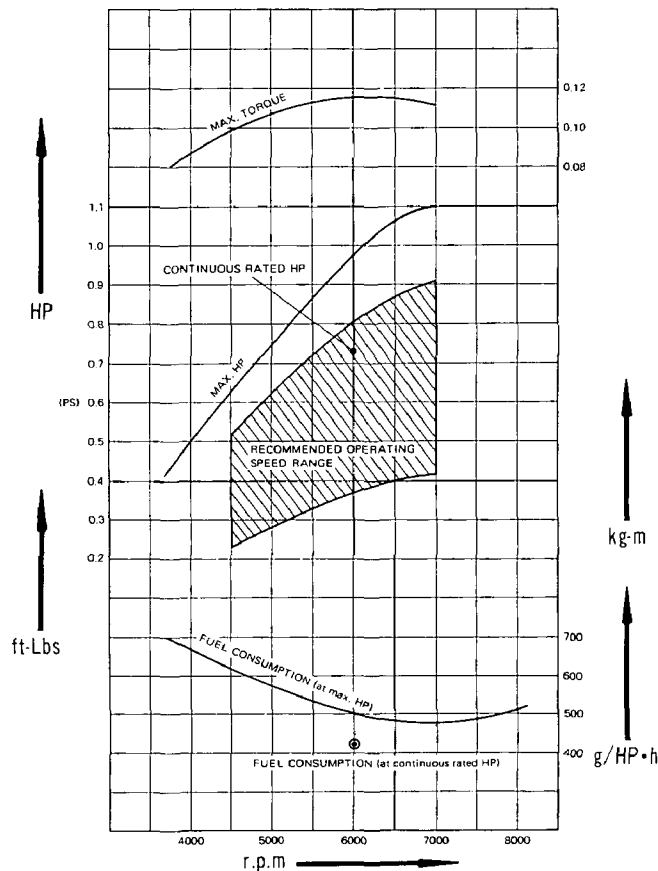

3. FEATURES

1. **COMPACT, LIGHT WEIGHT, HIGH PERFORMANCE and LOW FUEL CONSUMPTION**
2. **TROUBLE FREE** because of simple design and easy to handle
3. **HIGH DURABILITY** engine withstand long severe operation
4. **TILTED OPERATION AVAILABLE**
Be able to operate at any position due to diaphragm carburetor.
5. **EASY STARTING** with recoil starter
6. **Forged steel Crankshaft**
7. **Ball main bearings** at both ends
8. **Forged steel connecting rod.**
9. **With CHROME PLATED CYLINDER, HEAT CONDUCTIVITY and WEAR PROOF** are quite excellent.

4. DISASSEMBLY and REASSEMBLY

4-1 PREPARATION and SUGGESTIONS

- 1) When disassembling the engine, memorize the locations of individual parts so as to be able to reassemble them correctly. Tag parts if there is a possibility of confusion.
- 2) Prepare several boxes to keep parts belonging to certain groups together.
- 3) Group those parts related each other, tentatively assembling where they belong, immediately after removing, in order to prevent missing and misplacing.
- 4) Handle the disassembled parts carefully and wash them in kerosene.
- 5) Use the correct tools in the correct way.
- 6) Standard tools required for disassembling and reassembling:
 - a) Work table
 - b) Washing pan
 - c) Disassembling tools
 - d) Washing oil (kerosene or gasoline), 2 cycle-oil
 - e) Emery paper, cloth
- 7) Before starting to disassemble the engine, drain fuel.
- 8) Tighten the screws of the cylinder, crankcase, connecting rod, spark plug, and flywheel to the specified torque values.
- 9) Use new packings and gaskets in reassembly.
- 10) Immediately before assembling parts, wash them in fresh gasoline or kerosene and blow them dry.
- 11) Apply 2 cycle-oil on rotating and sliding parts.
- 12) Take care not to contaminate the parts by dust during assembling.
- 13) Tighten bolts, nuts and screws with proper torque according to the their sizes. If small screws are tightened too tight, they may get broken.
- 14) After completely assembling the engine; turn it by hand and check if there is any abnormality or loose members.

4-2 SPECIAL TOOLS (*Fig. 1*)

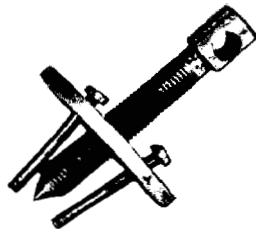

Fig. 1

4-3 DISASSEMBLY PROCEDURES

4-3-1 FUEL DRAIN

Drain fuel from the fuel tank.

4-3-2 THROTTLE WIRE (See Fig. 2)

Remove throttle wire from carburetor together with piston valve.

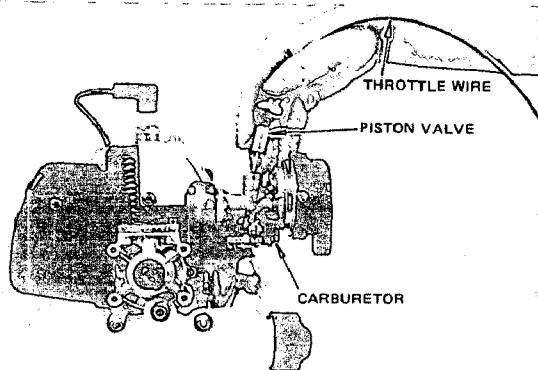

Fig. 2

4-3-3 FUEL TANK and RUBBER TUBE

- 1) Disconnect fuel pipe between fuel tank and carburetor at carburetor side.
- 2) Remove fuel tank by unscrewing bolts.
- 3) Only for EC02-R

After removing fuel pump, push the head of rubber tube toward arrow mark in Fig. 3 with a screwdriver of minus top (preferably not sharpened) and remove rubber tube.

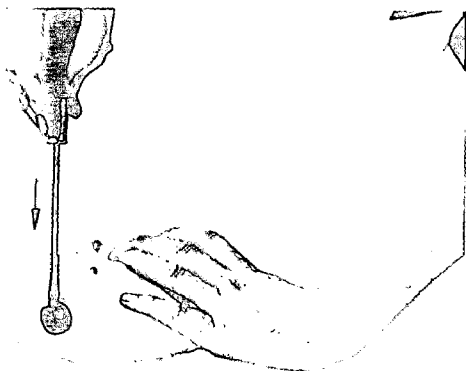

Fig. 3

CAUTION:

NEVER REMOVE RUBBER TUBE EXCEPT AT REPLACEMENT.

BE SURE TO REPLACE WITH NEW ONE WHEN REMOVED.

BE CAREFUL NOT TO DAMAGE THE HOLE IN WHICH RUBBER TUBE WILL BE INSERTED.

4-3-4 KILL SWITCH WIRE

Disconnect stop button wire terminal.

4-3-5 RECOIL STARTER

Remove starter case from crankcase by unscrewing bolts.

4-3-6 MAGNETO FLYWHEEL (See Fig. 4)

After removing nut, pull out flywheel from crankshaft.

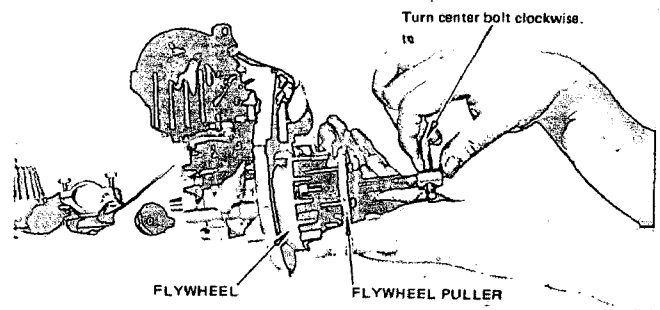

Fig. 4

4-3-7 BREAKER, CONDENSER, and COIL (See Fig. 5)

Remove breaker cover, condenser, breaker, and ignition coil from crankcase by unscrewing bolts.

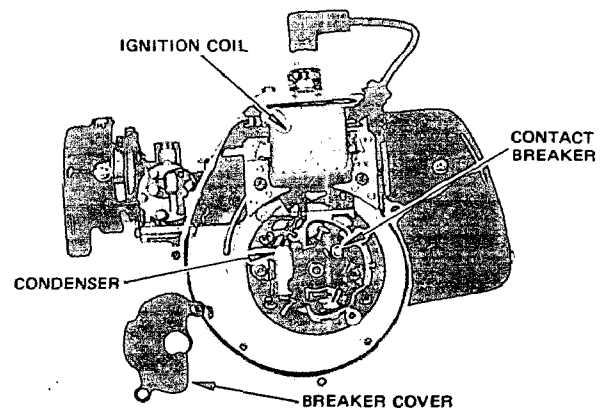

Fig. 5

4-3-8 CARBURETOR and CARBURETOR BRACKET (EC02-A), CARBURETOR and HEAT BLOCK (EC02-R) (See Fig. 6)

Remove carburetor and carburetor bracket by unscrewing bolts (EC02-A), and remove carburetor and heat block by unscrewing bolts (EC02-R).

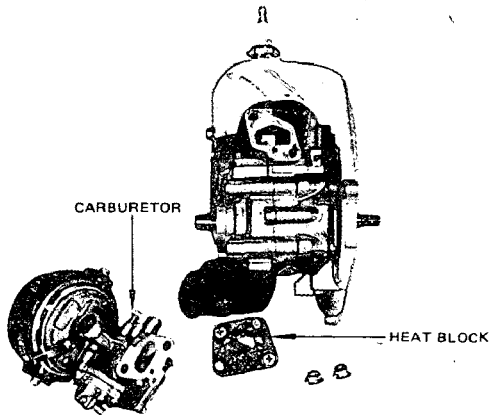

Fig. 6

4-3-9 MUFFLER

Remove muffler from cylinder by unscrewing bolts.

4-3-10 CYLINDER (See Fig. 7)

Remove cylinder quietly so as not to damage sliding surfaces of cylinder and piston.

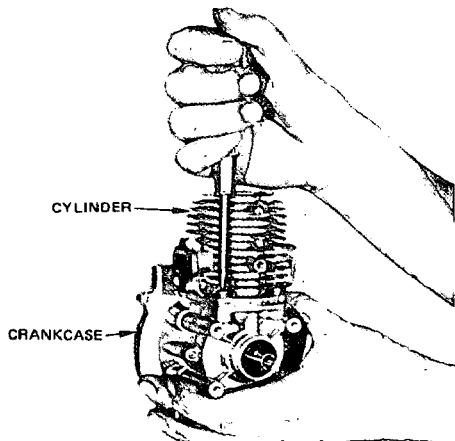

Fig. 7

4-3-11 DIVISION of CRANKCASE (See Fig. 8)

After unscrewing bolts, disassemble front and rear crankcases from crankshaft by tapping with a soft hammer. Washing crankcase with gasoline, apply the film of oil to crankcase ball bearing bore and grease to oil seal bore.

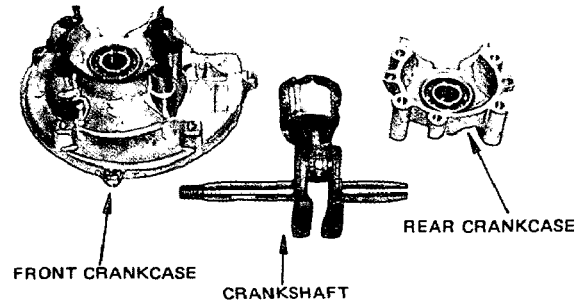

Fig. 8

4-4 REASSEMBLY PROCEDURES

4-4-1 CRANKCASE (See Fig. 9)

- 1) Insert crankshaft into front crankcase bearing.
- 2) Assemble the crankcase.
- 3) Use new gasket.
- 4) Tighten bolts to 40~50 kg-cm (2.9~36 ft-lbs) torque.
- 5) Cut off crankcase gaskets stuck out to the mating surface of cylinder.

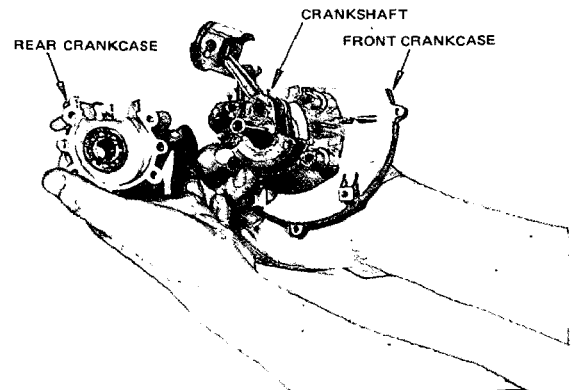

Fig. 9

4-4-2 CYLINDER (See Fig. 10)

- 1) Replace cylinder gasket with new one. At the same time, try to mate the taper hole with the groove on the contact surface of crankcase.

CAUTION:

TAKE CARE THAT GASKET IS PLACED IN RIGHT POSITION AND ON RIGHT SIDE.

- 2) In assembling cylinder, *take care of the position of piston rings and cylinder.*
- 3) Tighten bolts to 40~50 kg-cm (2.9~3.6 ft-lbs).

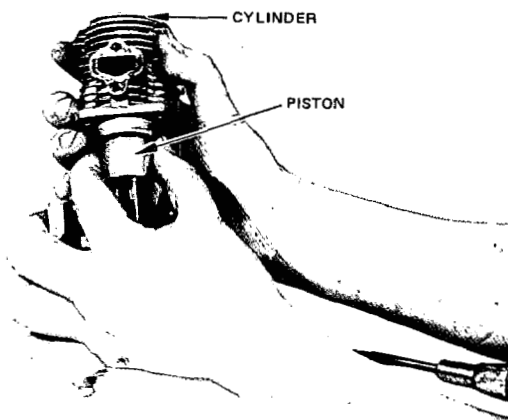

Fig. 10

4-4-3 SPARK PLUG

Tighten spark plug to 220~300 kg-cm (15.9~21.7 ft-lbs).

4-4-4 CARBURETOR BRACKET OR HEAT BLOCK

- 1) Use new gasket.
- 2) Tighten bolts to 50~70kg-cm (3.6~5.1 ft-lbs) torque for EC02-A and to 40~50kg-cm (2.9~3.6 ft-lbs) torque for EC02-R.

4-4-5 CARBURETOR (See Fig. 11)

Tighten nuts to 50~70kg-cm (3.6~5.1 ft-lbs) torque for EC02-A and to 40~50kg-cm (2.9~3.6 ft-lbs) torque for EC02-R.

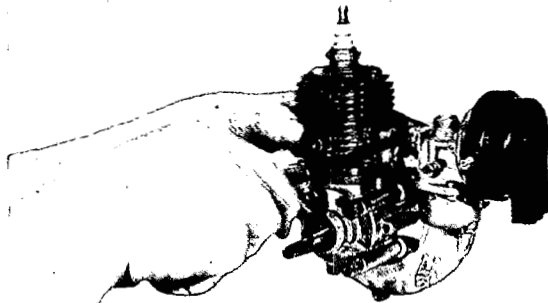

Fig. 11

4-4-6 IGNITION COIL

Tighten ignition coil tentatively, putting high tension wire on the right side.

4-4-7 BREAKER

Insert knock pin of breaker into the hole of crankcase.

Tightening torque: 25 kg-cm (1.8 ft-lbs).

Regarding the adjustment of spark timing, refer to *Section 5. Breaker Point adjustment Procedure.*

4-4-8 CONDENSER

Assemble it, running stop wire through the bottom of condenser.

Tightening torque: 25 ±2 kg-cm

Tool: Plus driver, Torque wrench

4-4-9 POINT COVER

After inserting stop wire and primary wire into the groove of crankcase, assemble point cover.

Tightening torque: 25 kg-cm (1.8 ft-lbs).

4-4-10 FLYWHEEL

Mount flywheel on crankshaft and tighten flywheel nut.

Flywheel tightening torque is 150~180 kg-cm (10.8~13.0 ft-lbs).

4-4-11 IGNITION COIL (See Fig. 12)

Tighten ignition coil, keeping a clearance of 0.4~0.6 mm from flywheel.

Tightening torque: 25 kg-cm (1.8 ft-lbs).

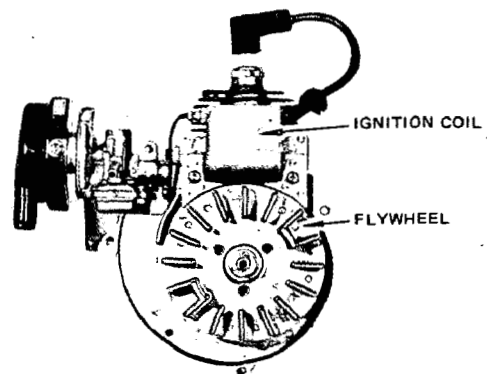

Fig. 12

4-4-12 MUFFLER

Tighten muffler to 90~110kg-cm (6.5~8.3 ft-lbs).

Use new gaskets.

4-4-13 TENTATIVELY TIGHTENING OF CYLINDER COVER

Mount the both ends of cylinder covers on the mating portions of the crankcase and tentatively tighten with screws. In Type A, also mount fuel tank stay together on the cylinder head with flat washers.

Tool: Plus Driver

4-4-14 RECOIL STARTER, STOP BUTTON AND GROMMET

Install stop button to starter case with toothed washer on its reverse side. Run high tension cord through the grommet and assemble plug cap spring and plug cap. Run the grommet through the groove of starter case and tighten starter case to crankcase with three screws.

Tightening torque: Stop button 25 ± 2 kg-cm

Starter case 45 ± 3 kg-cm

Tool: Plus driver, Torque wrench

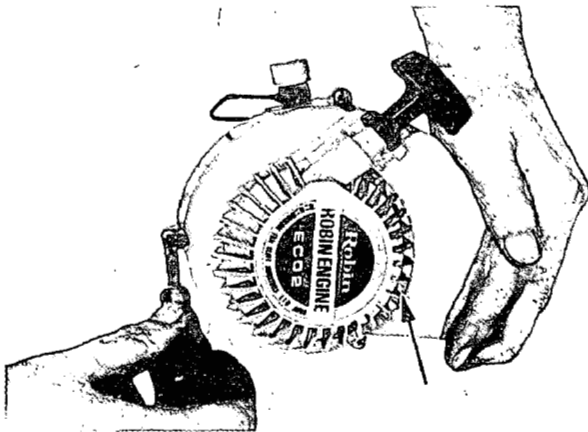

Fig. 13

4-4-15 TIGHTENING OF CYLINDER COVER

Tighten the cylinder cover.

Tightening torque: 45 ± 3 kg-cm

Tool: Plus driver, Torque wrench

4-4-16 RUBBER TUBE IN FUEL TANK (EC02-R)

Insert the rubber tube in the hole of fuel tank from the end of felt side of rubber tube. Use spacer or backing plate to gently put in with vice or squill vice as shown in the figures. Completely put in the ridge of rubber tube. After inserting, pinch the outer side of rubber tube and turn it to assure that the ridge has been completely inserted.

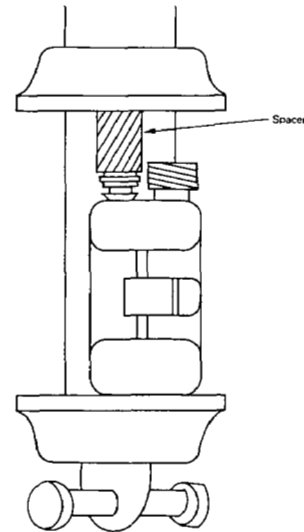

Fig. 14

CAUTION:

AFTER INSERTING, BE SURE TO CONFIRM THE INSERTION OF THE RIDGE OF RUBBER TUBE.



Fig. 15

4-4-17 FUEL TANK

Put spacer into fuel tank and install with screws. (Use a large type flat washer.) Connect fuel line to carburetor.

Tightening torque: 45 ± 3 kg-cm (3.3 ± 0.2 ft-lbs)

Tightening torque: 45 ± 3 kg-cm

Tool: Plus driver, Torque wrench

5. BREAKER POINT ADJUSTMENT PROCEDURES

- 1) Remove starter case.
- 2) Remove flywheel from crankshaft. (Flywheel nut is left-hand threads).
- 3) Take off woodruff key from crankshaft and point cover.
- 4) Remove carbon deposits on breaker point and clean mating surface by cloth or paper.
- 5) Fit woodruff key to crankshaft.
- 6) Tack flywheel, and set "F" on flywheel to the mark on crankcase. Then gently remove flywheel from crankshaft again. (See Fig. 16)
- 7) Adjust as per the Fig. 17 (under the condition stated in item 6).
 - a) Loosen breaker fitting screw.
 - b) Confirm open/close condition of point by pushing breaker in the direction of arrow. Adjust breaker so that point may be about to open. (Normal ignition timing will be $23^{\circ}\sim 27^{\circ}$)Notice that ignition timing will be over 30° if point is opening under the condition shown in Fig. 17.
- 8) Point cover, magneto, starter case shall be assembled in order after point has been adjusted.

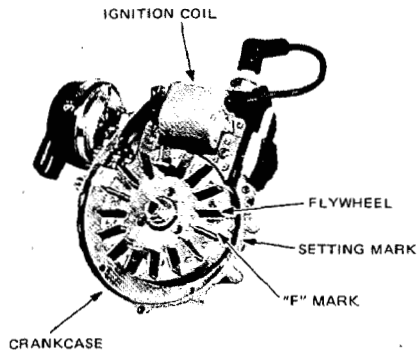

Fig. 16

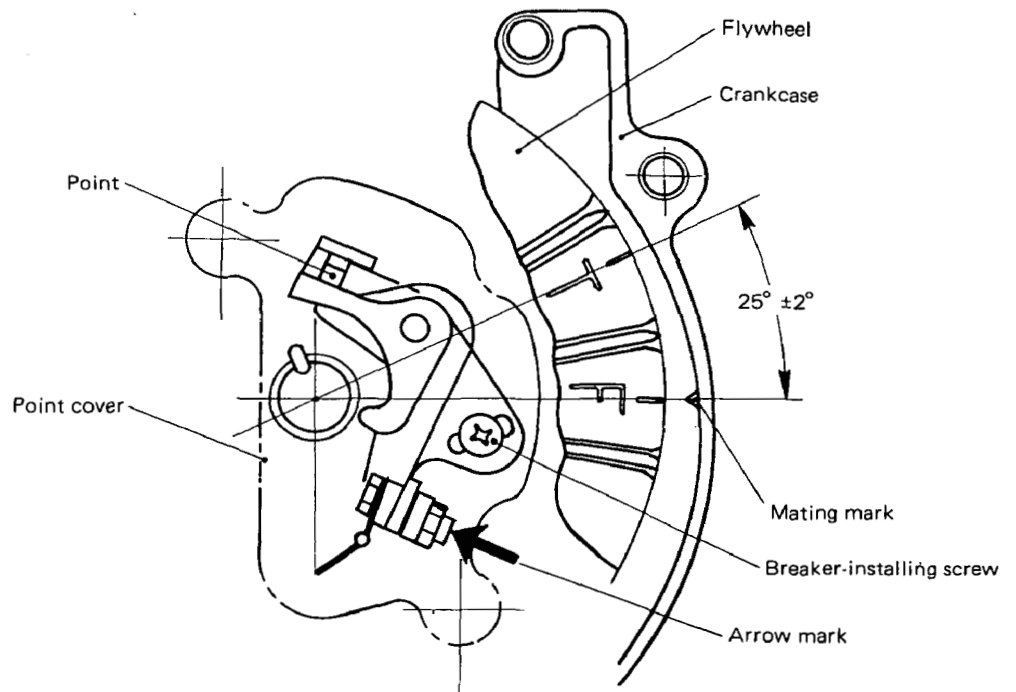

Fig. 17

6. CARBURETOR ADJUSTMENT

Since the carburetor has carefully been adjusted at shop before shipment, avoid adjusting it unless absolutely necessary. If adjustment are needed, refer to the following.

1) Idle adjustment (See Fig. 18) EC02-A, EC02-R

Adjust idling revolution with throttle stop screw. If turn throttle stop screw clockwise, revolution will increase. If turn it counter-clockwise, revolution will reduce.

CAUTION: DO NOT IDLE UNDER 2,800 r.p.m.

2) Fuel flow adjustment (See Fig. 18) EC02-R

a) At low speed (at the small opening of the throttle)

When fuel is too RICH, turn the low speed fuel adjusting screw to the LEFT. When it is too LEAN, turn low speed fuel adjusting screw to the RIGHT.

b) At high speed (at the large opening of the throttle)

When fuel is too RICH, turn high fuel adjusting screw to the RIGHT. When it is too LEAN, turn high speed fuel adjusting screw to the LEFT.

CAUTION: LOW SPEED FUEL ADJUSTING SCREW IS FOR ADJUSTMENT OF AIR AMOUNT, SO IT IS NOTED THAT THE DIRECTION OF TURNING SCREW IS REVERSE TO THAT OF HIGH SPEED FUEL ADJUSTING SCREW.

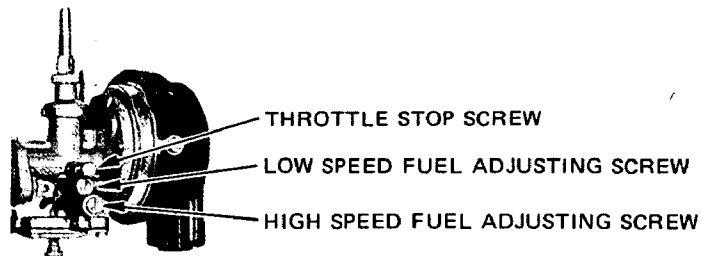

Fig. 18

7. OPERATION OF FLOAT AND DIAPHRAGM CARBURETORS

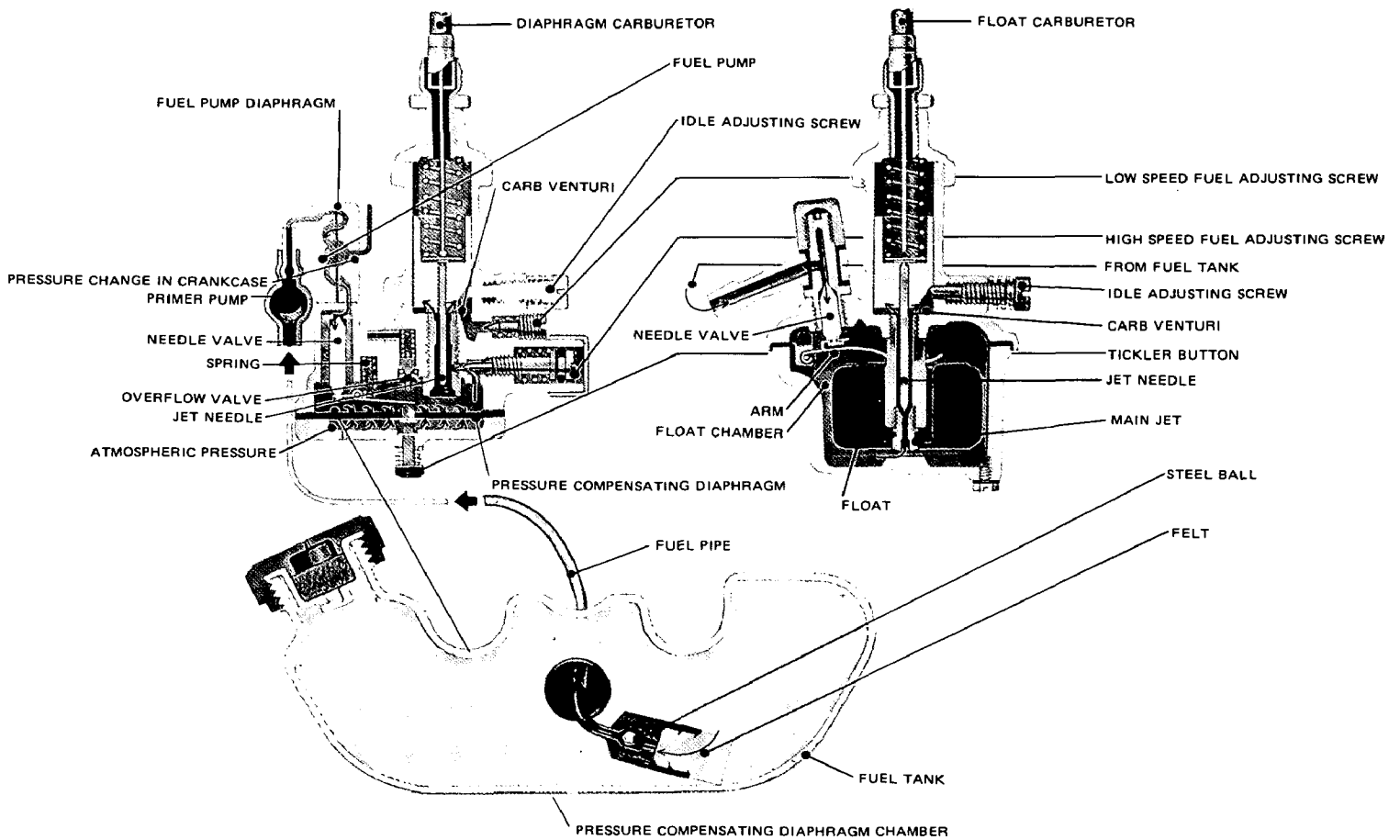

Fig. 19

7-1 OPERATION OF FLOAT CARBURETOR

- 1) Fuel from the fuel tank enters the float chamber through the needle valve, which is kept open while the fuel level is low.
- 2) When the fuel level rises, the float is allowed to move up and lift the arm connected to the needle valve.
- 3) The arm lifted by the float raises the needle valve, which shuts off the supply of fuel.
- 4) When the fuel in the float chamber is suctioned into the engine through the carb venturi, the fuel amount is measured by the main jet and the jet needle the fuel level falls low, causing the float to move down.
- 5) The falling of the float lowers the arm connected to the needle valve, which admits the fuel to enter the float chamber. After this, the same operations in 1) ~ 5) are repeated.

7-2 OPERATION OF DIAPHRAGM CARBURETOR

- 1) When the engine runs, positive pressure and negative pressure will alternately occur in the crankcase. This alternation in pressure is led to the reverse side of fuel pump diaphragm so that the top side will work as fuel pump.
- 2) The fuel drawn up by fuel pump enters pressure compensating diaphragm chamber through the felt, rubber tube in fuel tank, fuel pipe and needle valve.
- 3) The fuel in pressure compensating diaphragm chamber is sent by pressure, so that the fuel pressure becomes higher than atmospheric pressure and pushes down the pressure compensating diaphragm.
- 4) When the pressure compensating diaphragm is pushed downwards, the arm connected to needle valve turns clockwise by the strength of spring and pushes up the needle valve, which shuts out the supply of fuel.
- 5) The fuel in pressure compensating diaphragm chamber is measured by high speed fuel adjusting screw and jet needle, entering the engine through the carb venturi. Then, the pressure in pressure compensating diaphragm chamber becomes lower than atmospheric pressure and the diaphragm is pushed up against the strength of spring.
- 6) When the pressure compensating diaphragm is pushed up, the arm turns counterclockwise against the spring and lowers needle valve, which admits fuel to enter. After this, the same operations in 1) ~ 6) are repeated.

NOTE:

1. OPERATION OF LOW SPEED FUEL ADJUSTING SCREW

When the opening of the throttle is small, it is not sufficient to measure the fuel only by high speed fuel adjusting screw and jet needle. Therefore, even by low speed fuel adjusting screw, fuel is measured and sent to the venturi to adjust the density of fuel. Accordingly, in high and low speed fuel adjusting screws, the direction of turning the screw is reverse to each other. For instance, when the opening of the throttle is LARGE and the fuel is RICH, turn high speed fuel adjusting screw TO THE RIGHT to make the fuel lean, but when the opening of the throttle is SMALL and the fuel is RICH, turn low speed fuel adjusting screw TO THE LEFT to make the fuel lean.

2. OPERATION OF TICKLER BUTTON

- 1) *When tickler button is pushed up, the lever connected to needle valve turns left against the strength of spring, lowering needle valve, which allows fuel to enter.
At the same time, when the tickler button is pushed up, overflow valve is also held open through the lever.*
- 2) *In a condition of 1), if primer pump is repeatedly pushed, fuel is pumped up from the tank and air in pressure compensating diaphragm chamber is exhausted through the overflow valve, so that the pressure compensating diaphragm chamber is filled with fuel.*
- 3) *Further, when primer pump is operated continuously, fuel is forced to flow into the overflow pipe through the overflow valve and, at the same time, a little amount of fuel is sent to carb venturi through the high speed fuel adjusting screw and jet needle.*
- 4) *A little amount of fuel sent to carb venturi by the operation of 3), if recoil starter is pulled, it is taken into the engine, and becomes somewhat rich and suitable fuel for easy starting of the engine.*

8. TROUBLE SHOOTING

For a gasoline engine to start and run satisfactorily, the following three requirements must be met:

- 1) The cylinder filled with a proper fuel-air mixture.
- 2) An appropriate compression in the cylinder.
- 3) Good spark at correct time to ignite the mixture.

If all the three requirements are not met simultaneously, an engine can not be started. There are also other factors such as heavy load at starting and too long an exhaust pipe causing a high back pressure, which contribute to hard starting. The most common causes of engine troubles are given below.

8-1 STARTING DIFFICULTIES

	Cause	Remedy	Preventive measure
Little or No Spark	Defects in spark plug	<ol style="list-style-type: none"> 1) If contaminated, wash in gasoline, remove foreign material and dry. 2) If spark plug is broken and lost insulation, replace plug. 3) Adjust spark gap to 0.6~0.7mm (.024~.027"). 	<ol style="list-style-type: none"> 1) Use spark plugs of specified heat range. Do not use poor grade oil. Clean air cleaner and avoid dust entry. 2) When spark gap is adjusted, if center electrode is hit or bent, insulator may get damaged.
	Defects in contact cable	If cable is burnt, replace cable along with coil.	
	Defects in contact breaker	<ol style="list-style-type: none"> 1) If breaker points are rough, smooth out surface with emery paper (#400). 2) If breaker point gap is incorrect, adjust it to specified 0.35±0.05mm by loosening contact support plate lock screws. 3) If spark timing is incorrect, adjust it to 23° ~ 27° before TDC. 4) If breaker is defective in insulation, replace breaker. 5) If condenser is defective, replace. 	
	Defects in magneto	<ol style="list-style-type: none"> 1) If wire or insulation is broken, replace magneto. 2) If magnetism is weak, re-magnetize (at the magneto maker) or replace. 	
	Other defects in electric system	<ol style="list-style-type: none"> 1) If kill switch is faulty, (short circuiting) replace or repair. 2) If primary wire is grounded to the engine body, insulate it with insulating adhesive tape. 	
Little or No Compression	Gas leak from combustion chamber	<ol style="list-style-type: none"> 1) If spark plugs are loose, tighten. 2) If spark plugs are defective, replace. 	
	Defects in piston assembly	<ol style="list-style-type: none"> 1) If piston is worn, replace. 2) If piston rings are worn, replace. 3) If piston rings are stuck, clean or replace rings. 	<ol style="list-style-type: none"> 1) Keep air cleaner always clean. 2) Do not use poor grade oil. Change oil regularly.
Not Fuel Supply	Defects in fuel tank system	<ol style="list-style-type: none"> 1) Clean clogged tank outlet. 2) Clean clogged fuel strainer. 3) If incorrect fuel is poured into tank or water is mixed, drain tank completely and fill it with correct fuel. 4) When fuel pipe is locked with air, expell air. 5) If there is any crack or damage in the rubber components of fuel line system, due to their deterioration, replace. 	<ol style="list-style-type: none"> 1) Be sure to use a filter when adding fuel. 2) Use mixture (gasoline 20 ~ 25 : oil 1) as fuel.

	Cause	Remedy	Preventive measure
No Fuel Supply	Defects in carburetor	1) If clogged with dust, clean. 2) If defective, replace. Clean jets and other orifices, if they are clogged.	
Excessive Fuel		1) Start engine with fully open choke valve and fully open throttle valve. 2) Remove spark plug and disconnect fuel pipe, repeat starting operation several times to evacuate excess fuel.	1) Never close choke valve when engine is warm. 2) When stopping the engine, run it at slow speed for a while. This practice not only favourably affects next starting, but also improves engine life. 3) Clogged air-cleaner results in too rich air-fuel mixture. Clean it thoroughly.
	Defects in carburetor	If fuel overflows, check needle valve seat for wear. Replace, if necessary.	Be careful clogged carburetor.
Too much resistance in starting	Piston or Connecting Rod seized	1) If piston seizes, correct or replace. 2) If connecting rod large end or small end seize, replace.	1) Do not use poor grade oil. 2) Use fuel of proper mixing ratio.

8-2 OVERHEATING

- 1) If the ignition timing is too far advanced, correct to $23^{\circ} \sim 27^{\circ}$
- 2) If too much carbon deposits in the combustion chamber, remove it.
- 3) If the heat range of the spark plug is too cool, replace it with correct one (NGK BM7A).
- 4) If the air-fuel mixture is too lean, clean jets and other holes in the carburetor. Clean the aircleaner also.
- 5) If the load is in excess, reduce it below the specified continuous load.

8-3 POWER DROP

- 1) If the cylinder, piston or piston rings are worn, replace them.
- 2) If the carburetor is out of order, re-adjust or clean it.
- 3) If the spark plug is faulty (contamination, gas leakage or faulty insulation), clean it or replace it.
- 4) If the magneto or the contact breaker is faulty, replace them or re-adjust them.
- 5) If the aircleaner is clogged, clean it.
- 6) If the fuel system is clogged, clean it.
- 7) If the oil seals at the crankshaft are worn and let the compressed gas through, replace them.

8-4 EXCESSIVE FUEL CONSUMPTION

- 1) If too rich air-fuel mixture, clean jets and small holes in carburetor.
- 2) If fuel leakage, re-tighten screws or replace.
- 3) If beside these causes, also caused by power drop, perform remedies for power drop, according to 7-3. POWER DROP.

8-5 ENGINE HUNTING

If the fuel-air mixture is too lean, Clean the carburetor.

8-6 OTHER COMPLAINTS

1) Fuel overflow from carburetor

If the fuel flows towards the aircleaner or much fuel flows into the crankcase while the engine is standing still (overflowing), the needle valve or the float is faulty. Correct or replace them.

2) If the engine suddenly stops with abnormal noise, the piston or the crankshaft and connecting rod assembly is seized. Correct them or replace them.

3) If the engine produces abnormal noise during operation, be sure to stop the engine and do not start it again before the cause is found.

If the cause for the trouble is not found, contact our distributor and entrust the engine in the hand of our service engineer.

9. CHECKS and CORRECTIONS

After disassembling and cleaning the engine parts, check them, and if necessary, correct them according to the correction table. The correction table applies whenever engine are repaired. Its contents should be thoroughly understood by those who undertake the repairing. Its specifications must be abided by to effect correct maintenance.

Below, terms employed in the correction table as explained.

1) **CORRECTION**

All operations performed on the engine parts for the purpose of improving or recovering the engine performance, consisting of repairs, readjustments, and replacements.

2) **STANDARD SIZE**

The design dimensions of the part without the tolerance.

3) **CORRECTION TOLERANCE**

The tolerance on the re-finished part dimension or on the readjusted dimension.

4) **CORRECTION LIMIT**

The limit on the part and adjustment, beyond which any dimensional and functional changes, due to wear, burn, and other causes will adversely affect the normal engine performance.

5) **USE LIMIT**

The limit, beyond which the part is no longer usable, due to defects in function or strength.

NOTE: ALL DIMENSIONS IN THE "CORRECTION TABLE" are given in millimeter, except where otherwise specified.

	ITEM	kg-cm	ft-lbs	TOOL
Specified Tightening Torque	Breaker, condenser point cover, & ignition coil	23 ~ 27	1.7 ~ 1.9	Torque Wrench
	Carburetor	42 ~ 48	3.0 ~ 3.5	
	Crankcase	42 ~ 48	3.0 ~ 3.5	
	Tank, starter case	42 ~ 48	3.0 ~ 3.5	
	Heat Block	42 ~ 48	3.0 ~ 3.5	
	Cylinder & muffler	42 ~ 48	3.0 ~ 3.5	
	Flywheel	150 ~ 180	10.8 ~ 12	
	Spark plug	220 ~ 300	15.9 ~ 21.7	

CORRECTION TABLE

	ITEM	STANDARD SIZE	CORRECTION LIMIT	REMARKS	TOOL	CORRECTION METHOD
Piston & Cylinder	Clearance between cylinder & piston	0.020L – 0.057L	0.12L			Replace
	Cylinder bore	32.01 dia	32.01 dia. +0.04	at middle portion	Cylinder gauge	Replace
	Piston O.D.	31.99 dia.	31.99 dia. -0.05	at middle portion	Micrometer	Replace
	Side clearance of piston ring	0.01L – 0.08L	0.13L		Feeler gauge	Replace
	Width of ring groove	1.6	1.6 +0.08	Max. width of ring groove	Block gauge	Replace
	Ring width	1.6	1.6 -0.05	Min. ring width	Micrometer	Replace
	Ring gap	0.1 – 0.3	0.6		Feeler gauge	Replace
	Clearance between piston & piston pin	0.007T – 0.008L	0.03L			Replace
	Piston pin hole	8 dia.	8 dia +0.02	Max. inner dia.	Cylinder gauge	Replace
Piston pin O.D.	8 dia.	8 dia. -0.01	Min. outer dia.	Micrometer	Replace	
Crankshaft & Connecting Rod	Side clearance of connecting rod large end	0.1L-0.5L	0.7L		Feeler gauge	Replace
	Run-out of crankshaft	0.05	0.1	Supporting assembled crankshaft between centers, measure journal where is 5mm from crankcase	Dial gauge	Correct
	Axial clearance of crankshaft journal	0.05 – 0.6	0.8		Dial gauge	Replace
	Tightness of main bearing outer dia.	0.014T – 0.036T	0			Replace
	Housing inner dia.	28 dia.	28 dia. -0.01		Cylinder gauge	Replace
	Bearing O.D.	28 dia.	28 dia. -0.01		Micrometer	Replace
	Clearance of main bearing I.D.	0.008T – 0.008L	0.014L			Replace
	Bearing inner dia.	12 dia.	12 dia. +0.003		Cylinder gauge	Replace
	Crankshaft O.D. dia.	12 dia.	12 dia. -0.011		Dial gauge	Replace
Connecting rod small end I.D.	11 dia.	11 dia +0.02				
Electric Equipment	Ignition timing	25° before top dead center	±2°		Timing tester	Adjust
	Point gap	0.35	+0.05 -0.05		Feeler gauge	Adjust
	Air gap	0.2	+0.1 0		Feeler gauge Thickness gauge	Adjust
	Spark plug gap	0.6~0.7	±0.1		Feeler gauge	Adjust

10. MAINTENANCE and STORING

The following maintenance jobs apply when the engine is operated correctly under normal conditions. The indicated maintenance intervals are by no means guarantees for maintenance free operations during these intervals. For example, if the engine is operated in extremely dusty conditions, the air cleaner should be cleaned every day, instead of every 50 hours.

10-1 DAILY CHECKS and MAINTENANCE

- 1) Remove dust from whatever which accumulated dust.
- 2) Check external fuel leakage. If any, retighten or replace.
- 3) Check screw tightening. If any loose one is found, retighten.

10-2 EVERY 50 HOURS CHECKS and MAINTENANCE

- 1) Check spark plug. If contaminated, wash in gasoline or polish with emery paper.
- 2) Clean air cleaner.

10-3 EVERY 150 HOURS CHECKS and MAINTENANCE

- 1) Clean fuel strainer and fuel tank.
- 2) Clean contact breaker points.
- 3) Clean exhaust port of cylinder and both inlet and outlet of muffler.

10-4 YEARLY CHECKS and MAINTENANCE

- 1) Remove carbon from cylinder head and piston head.
- 2) Clean fuel tank inside.
- 3) Clean carburetor diaphragm chamber inside. (In type A, float chamber inside)
- 4) Clean contact breaker and adjust point gap.
- 5) Replace fuel line once a year.

10-5 PREPARATION for LONG ABEYANCE

- 1) Perform the above 9-1 and 9-2 maintenance jobs.
- 2) Drain fuel from the fuel tank and carburetor float chamber. (In case type R with diaphragm carburetor, run the engine until it stops from lack of fuel.)
- 3) Remove spark plug, and apply 5 to 10cc of lubricating oil through the spark plug hole. Perform idle operation several times by pulling the recoil starter handle slowly. Re-install the spark plug.
- 4) Clean the engine outside with oiled cloth.
- 5) Put a vinyl or other cover over the engine and store the engine in dry place.

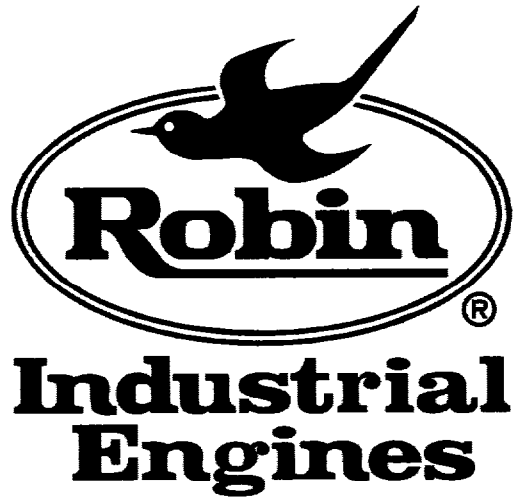

Robin America, Inc.

940 Lively Blvd., Wood Dale, IL 60191 • Tel: (708) 350-8200 • Fax: (708) 350-8212